



HIGH POWER BROADBAND ECM HORN ANTENNAS

1/3

DATA
SHEET
No. B115
1 of 10

- 3:1 BANDWIDTH
- COMPACT SIZE
- CIRCULARLY POLARIZED
- LOW AXIAL RATIO

P/N: 1030

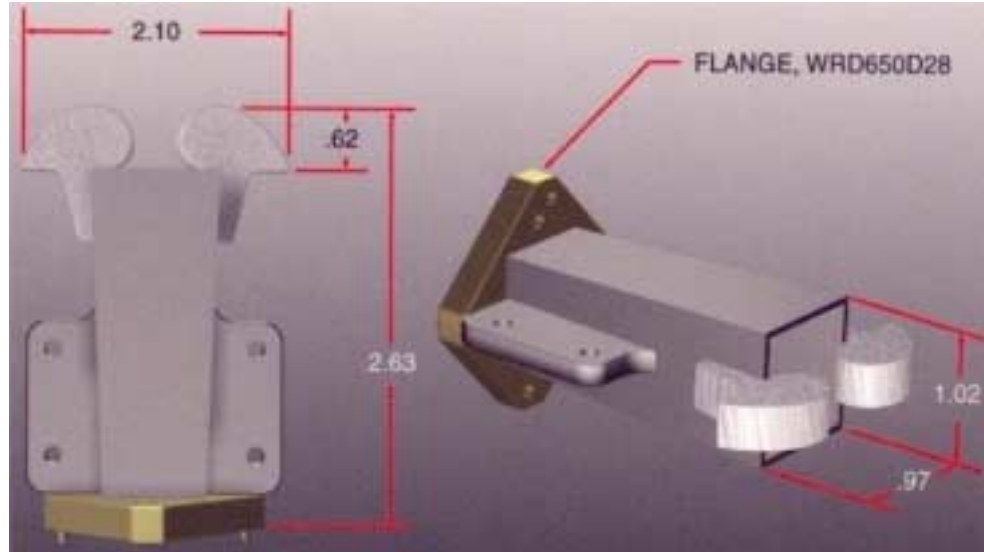

DESCRIPTION

MEC's 3:1 bandwidth horn series are quadridge designs which offer both symmetrical and asymmetrical beam coverage in azimuth and elevation planes. The lens – horn version utilizes a pair of dielectric lenses to broaden the beamwidth in one particular plane, for example, azimuth plane, and to control off – axis axial ratios as well.

All unites offer low VSWR, high power handling capability, compact size, and are suitable for airborne ECM applications.

Both waveguide and coaxial input versions available.

SPECIFICAITONS

MODEL NUMBER	FREQUENCY (GHz)	INPUT INTERFACE	GAIN (dBiL)	NOMINAL 3-dB BEAMWIDTH (degrees)		CW POWER (WATTS)	POLARIZATION	MAXIMUM AXIAL RATIO (dB)	MAXIMUM VSWR
				AZIMUTH	ELEVATION				
1030*	6 – 18	WRD-650	0 to 5	110	55	400	RCP OR LCP	3	1.7
1055*	6 – 18	TNC	0 to 5	110	55	200	RCP OR LCP	3	2.0
1070*	6 – 18	WRD-650	1 to 8	60	55	400	RCP OR LCP	3	1.7
1095*	6 – 18	TNC	1 to 8	60	55	200	RCP OR LCP	3	2.0
1120*	2.5 – 7.5	SC	0 to 5	100	55	400	RCP OR LCP	3	2.0
1145*	2.5 – 7.5	SC	1 to 8	60	55	400	RCP OR LCP	3	2.0

Data subject to change without notice



MICROWAVE ENGINEERING CORPORATION

1551 OSGOOD STREET, NORTH ANDOVER, MA 01845 • TEL (978) 685-2776 • FAX (978) 975-4363

Website: www.microwaveeng.com, Email: sales@microwaveeng.com



HIGH POWER BROADBAND ECM HORN ANTENNAS

2/3

DATA
SHEET
No. B115
2 of 10

ORDERING INFORMATION

*To specify right-hand or left-hand circular polarization, add suffix "R" or "L" to model number.

For example: 1030R is right-hand circular polarization.
1030L is left-hand circular polarization.

P/N:1055

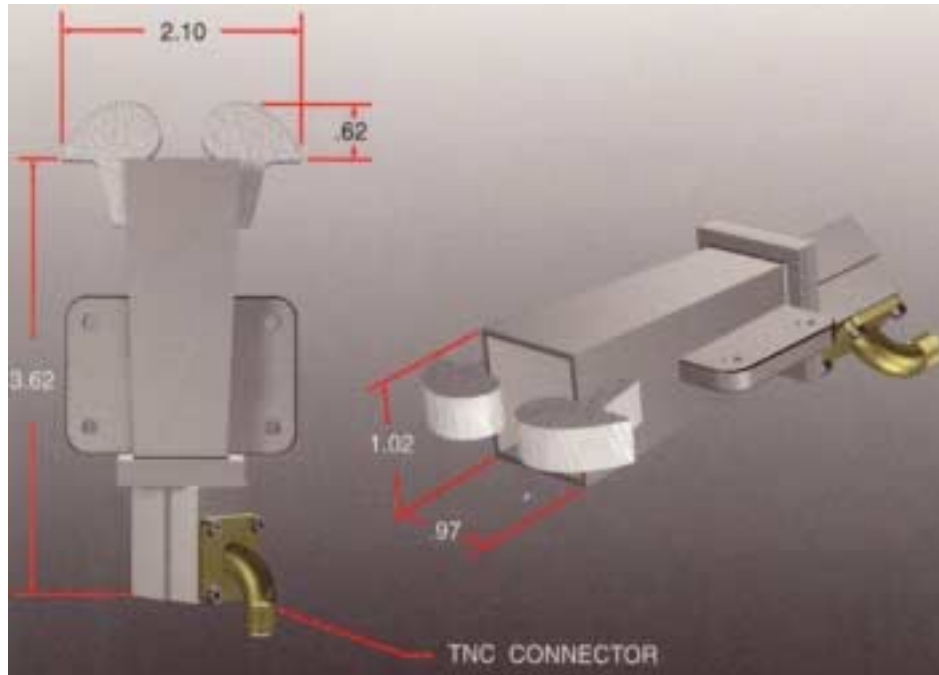

P/N: 1070

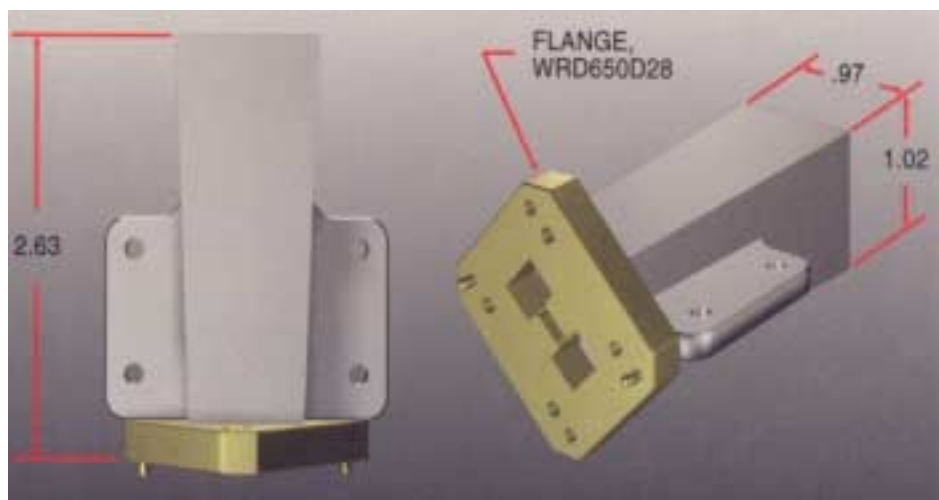

Data subject to change without notice

m.e.c

MICROWAVE ENGINEERING CORPORATION
1551 OSGOOD STREET, NORTH ANDOVER, MA 01845 • TEL (978) 685-2776 • FAX (978) 975-4363
Website: www.microwaveeng.com, Email: sales@microwaveeng.com



HIGH POWER BROADBAND ECM HORN ANTENNAS

DATA
SHEET
No. B115
3 of 10

3/3

P/N: 1095

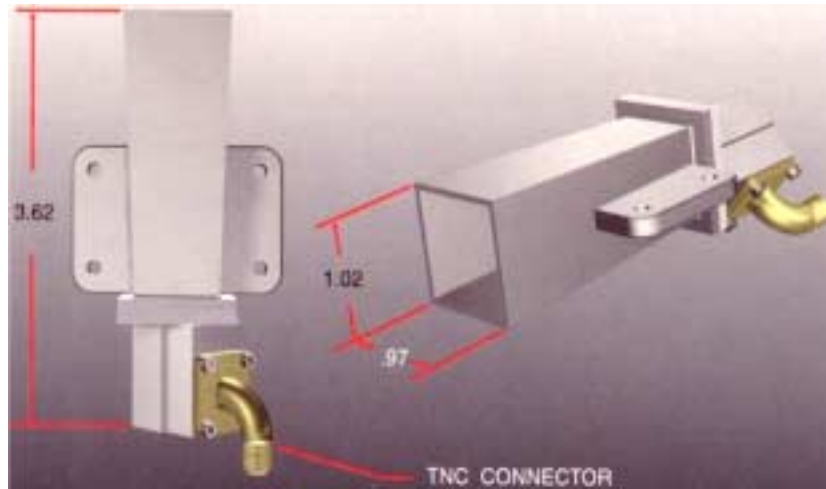

P/N: 1120

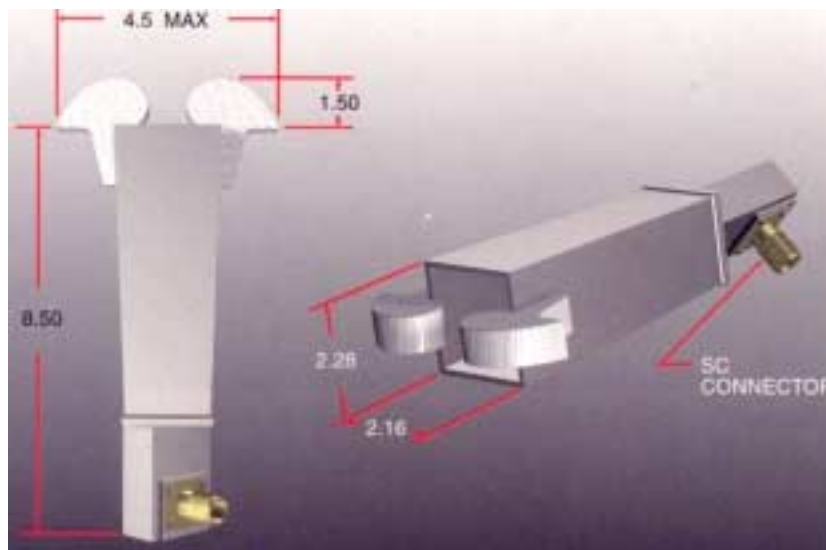

P/N: 1145

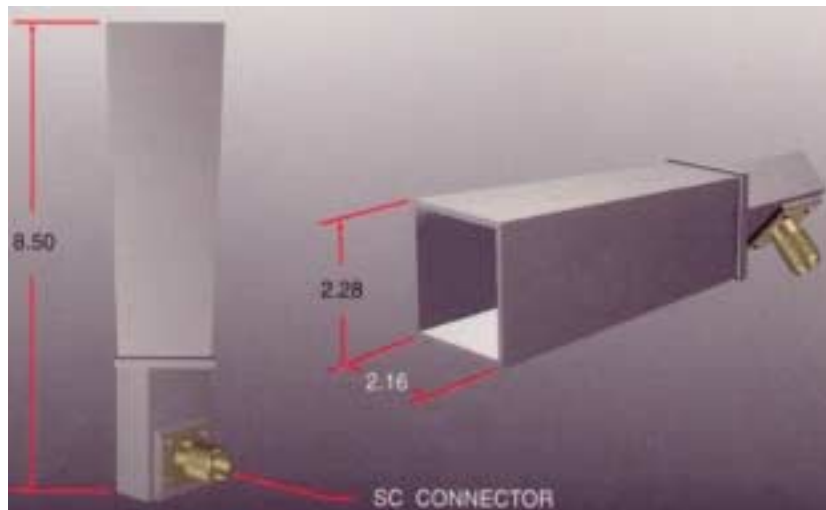

Data subject to change without notice



MICROWAVE ENGINEERING CORPORATION
1551 OSGOOD STREET, NORTH ANDOVER, MA 01845 • TEL (978) 685-2776 • FAX (978) 975-4363
Website: www.microwaveeng.com, Email: sales@microwaveeng.com



CAVITY BACKED SPIRAL ANTENNAS

DATA SHEET
No. B115
4 of 10

1/2

- MULTI – OCTAVE BANDWIDTH
- CIRULARLY POLARIZED
- CONSTANT BEAMWIDTH
- LOW AXIAL RATIO

P/N:2010

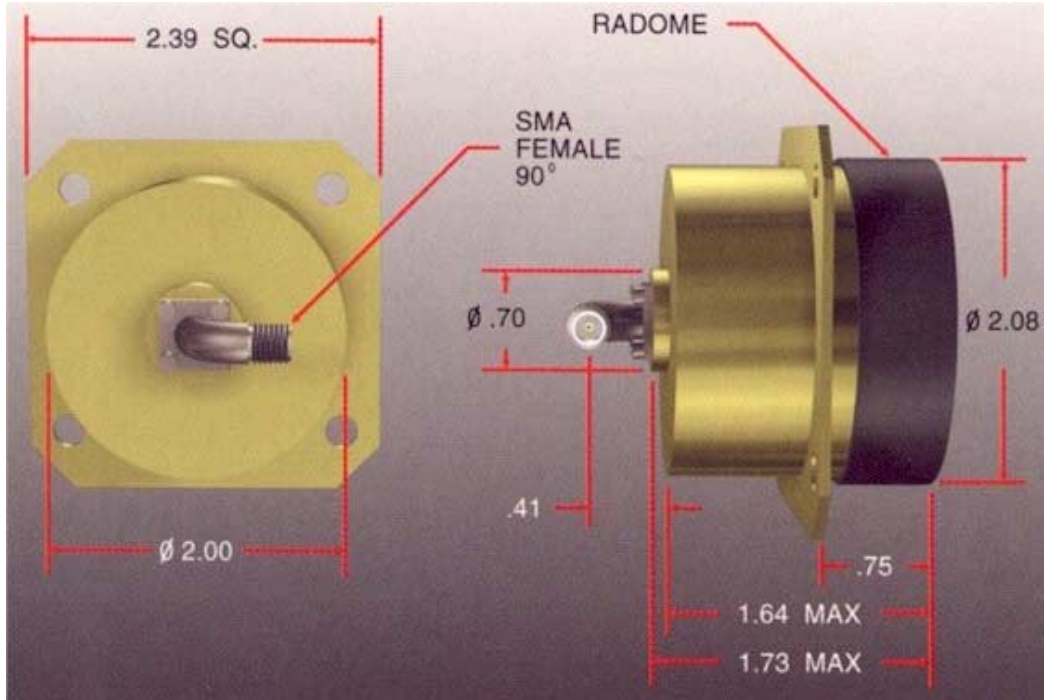

DESCRIPTION

MEC's cavity backed spiral series offer constant beamwidth, low axial ratio, and wide-band performances. These antennas utilize tapered line balun design which yields excellent repeatability in electrical performances from unit to unit and can be amplitude or phase matched in pairs or in groups.

All units offer low VSWR, light weight, compact size, and are suitable for airborne's or shipboard's Direction Finding System or Radar Warning Receiver applications.

SPECIFICAITONS

MODEL NUMBER	FREQUENCY (GHz)	INPUT INTERFACE	GAIN (DbiL)	NOMINAL 3-dB BEAMWIDTH (degrees)	BEAM SQUINT (degrees)	CW POWER (WATTS)	POLARIZATION	MAXIMUM AXIAL RATIO (dB)	MAXIMUM VSWR
2010	2 – 18	SMA	-7 TO 1	80	< 6	5	LCP	1.5	2.3
2010-1	2 – 18	SMA	-7 TO 1	80	< 6	5	LCP	1.5	2.3
2040	0.5 – 2.0	SMA	-12 TO 1	80	< 6	10	LCP	1.5	2.3
2040-1	0.5 – 2.0	SMA	-12 TO 1	80	< 6	10	LCP	1.5	2.3

Data subject to change without notice



MICROWAVE ENGINEERING CORPORATION
 1551 OSGOOD STREET, NORTH ANDOVER, MA 01845 • TEL (978) 685-2776 • FAX (978) 975-4363
 Website: www.microwaveeng.com, Email: sales@microwaveeng.com



CAVITY BACKED SPIRAL ANTENNAS

DATA
SHEET
No. B115
5 of 10

2/2

P/N: 2010-1

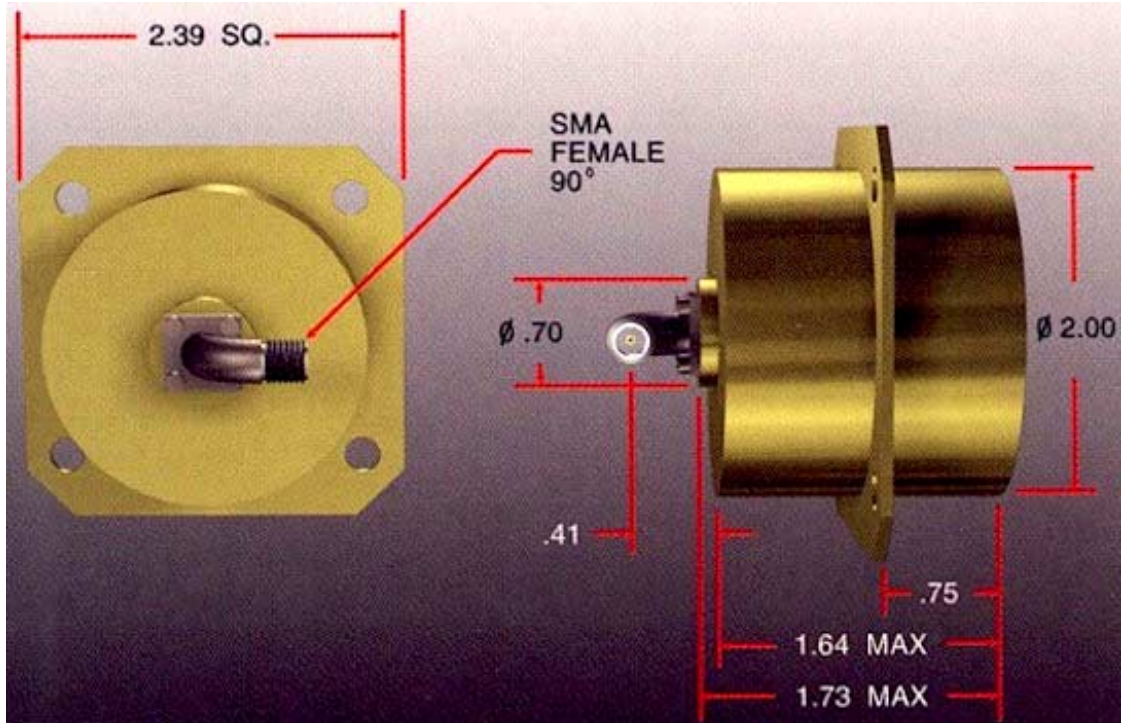

P/N: 2040
2040-1

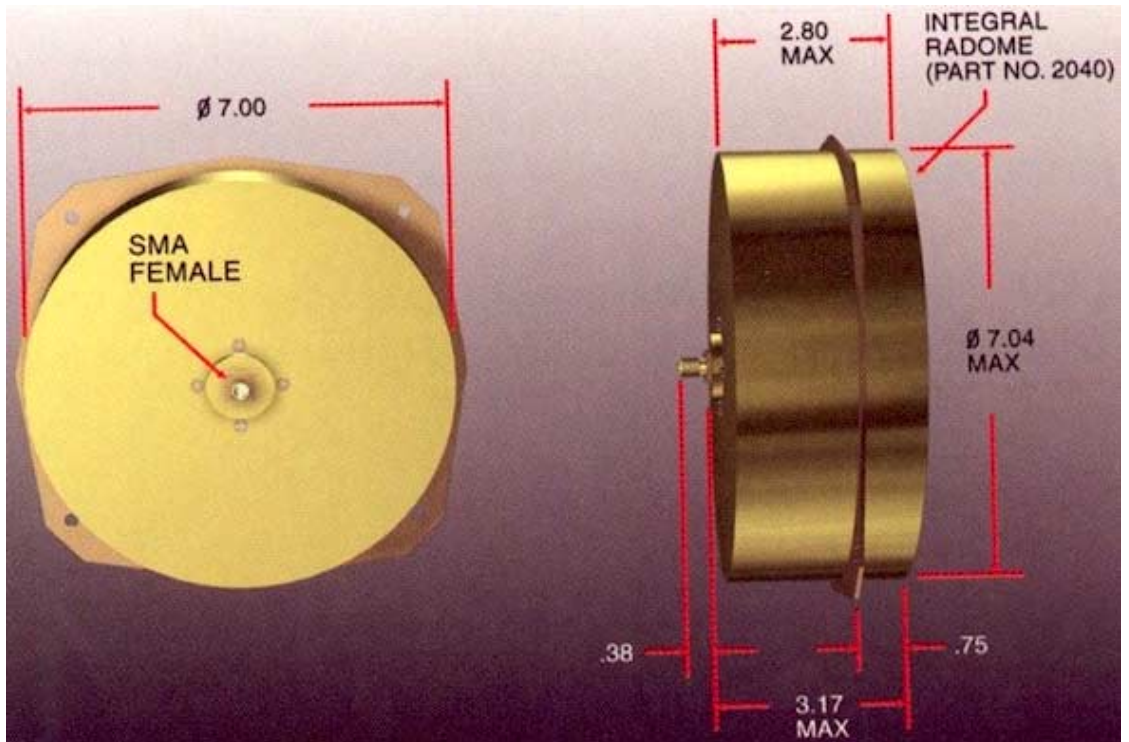

Data subject to change without notice



MICROWAVE ENGINEERING CORPORATION
1551 OSGOOD STREET, NORTH ANDOVER, MA 01845 • TEL (978) 685-2776 • FAX (978) 975-4363
Website: www.microwaveeng.com, Email: sales@microwaveeng.com



BICONICAL ANTENNAS

DATA SHEET
No. B115
6 of 10

- BROAD BANDWIDTH
- SLANT LINEAR POLARIZATION
- OMNIDIRECITONAL PATTERN

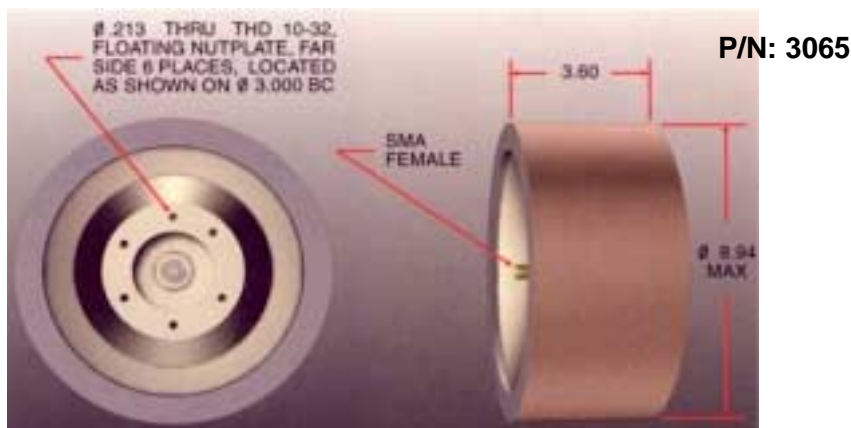
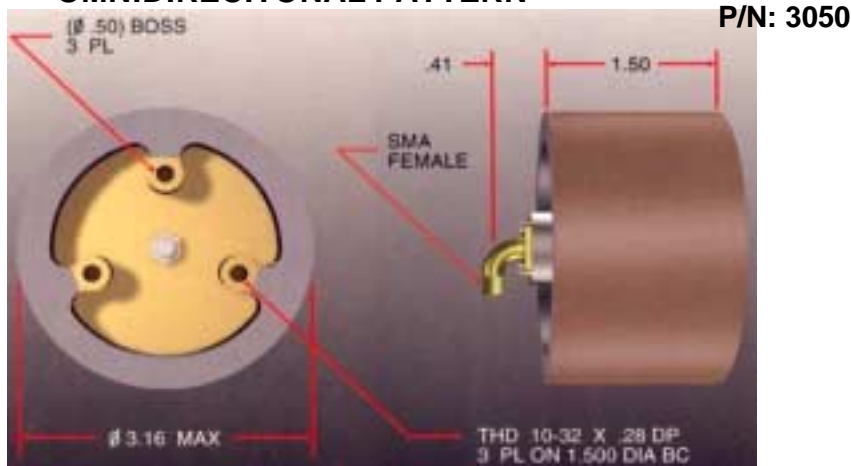

DESCRIPTION

MEC's biconical antennas offer broadband performance with omnidirectional azimuth coverage. The antenna is enclosed by broadband polarizer which produces slant linear polarized waves. All units are sealed and are suitable for airborne and shipboard environments.

SPECIFICATIONS

MODEL NUMBER	FREQUENCY (GHz)	GAIN (dBiL)	NOMINAL 3-dB BEAMWIDTH	MAXIMUM VSWR	POLARIZATION	CW POWER (WATTS)	INPUT INTERFACE
3050	6-18	0 to 5	30° min	2.0:1	Slant 45° Linear	10	SMA
3065	2-6	0 to 5	30° min	2.0:1	Slant 45° Linear	80	SMA
3080	2-18	0 to 8	12° min	2.0:1	Slant 45° Linear	80	SMA
3120	18-40	0 min	30° min	2.5:1	Slant 45° Linear	2	K
T390-317	39-42	4	30°	1.5:1	Vertical	100	WR-22

Data subject to change without notice



MICROWAVE ENGINEERING CORPORATION
1551 OSGOOD STREET, NORTH ANDOVER, MA 01845 • TEL (978) 685-2776 • FAX (978) 975-4363
Website: www.microwaveeng.com, Email: sales@microwaveeng.com



STUD ANTENNAS

DATA SHEET
No. B115
7 of 10

- BROAD BANDWIDTH
- VERTICALLY POLARIZED
- OMNIDIRECITONAL PATTERN
- HIGH - POWER

P/N: C390-143

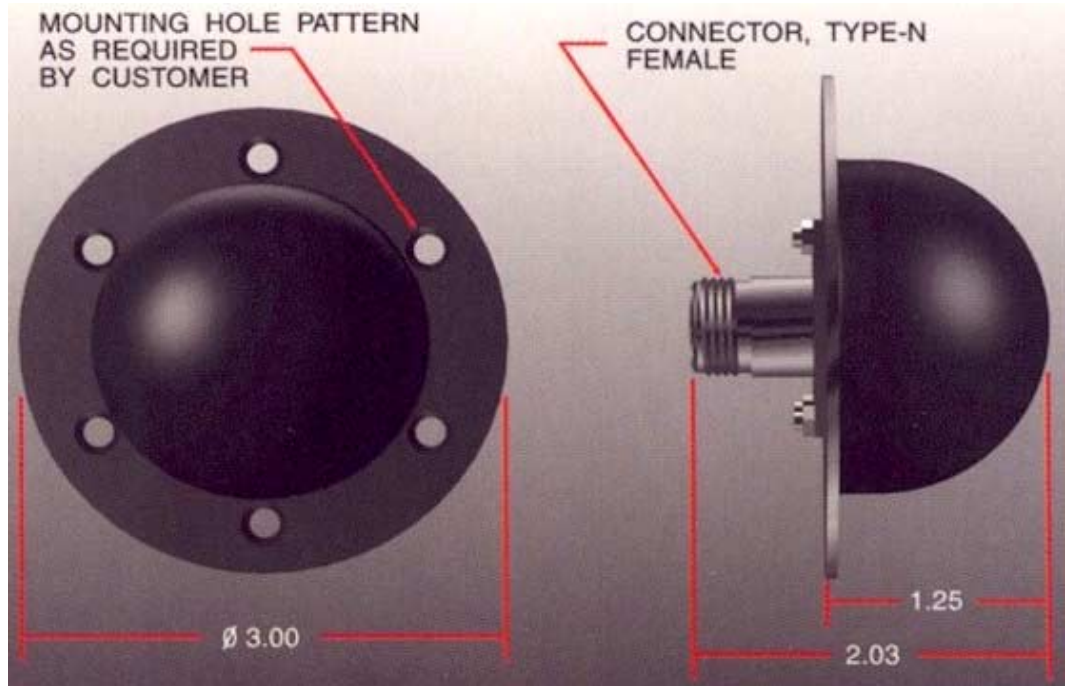

DESCRIPTION

MEC's C390-143 broadband stub antenna is monopole design which features omnidirectional azimuth pattern and high power handling capability. The stub radiating element is enclosed by a hemispherical shape radome. This antenna meets the environmental requirements of MIL-E-5400, Class 1 equipment. All units offer low VSWR, light weight, compact size, and are suitable for high speed aircraft.

SPECIFICATIONS

MODEL NUMBER	FREQUENCY (GHz)	GAIN (dB)	MAXIMUM VSWR	POLARIZATION	CW POWER (WATTS)	INPUT INTERFACE
C390-143	2 - 12	0 TO 5	2.5:1	Vertical	100	N - Type

Data subject to change without notice



MICROWAVE ENGINEERING CORPORATION
1551 OSGOOD STREET, NORTH ANDOVER, MA 01845 • TEL (978) 685-2776 • FAX (978) 975-4363

Website: www.microwaveeng.com, Email: sales@microwaveeng.com



L-BAND ANNULAR SLOT ANTENNAS

DATA SHEET
No. B115
8 of 10

- FLUSH – MOUNTED
- VERTICALLY POLARIZED
- OMNIDIRECTIONAL PATTERN
- LIGHT WEIGHT

P/N: C390-152

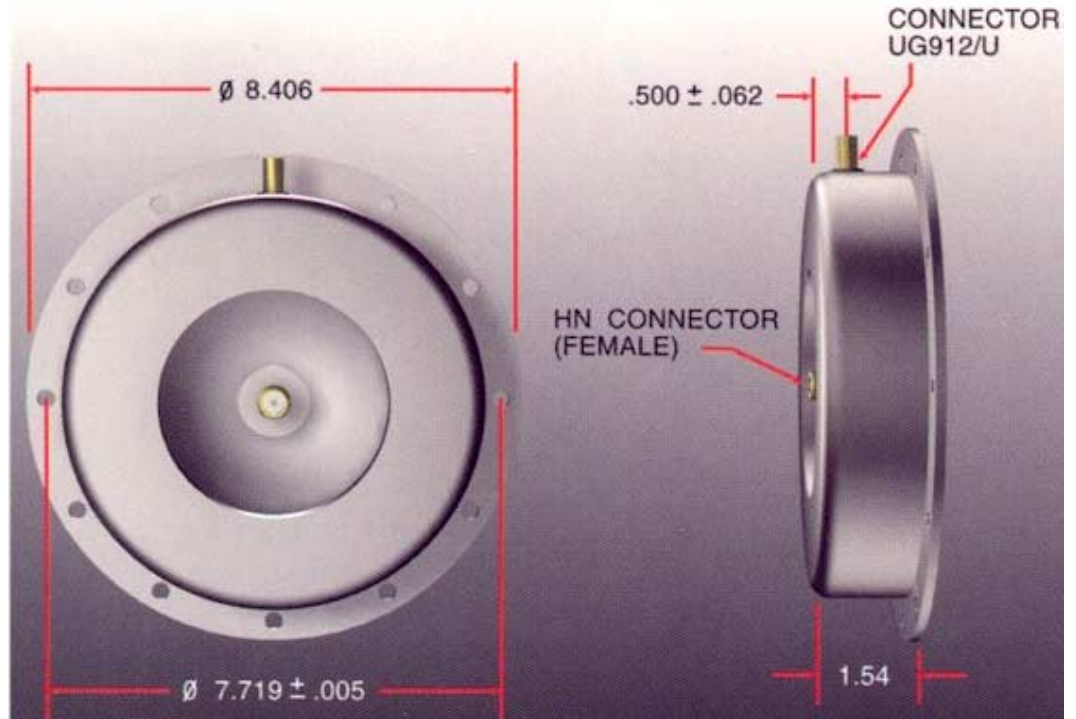

DESCRIPTION

MEC's L-Band annular slot antenna features omnidirectional azimuth pattern and high peak power handling capability. Its radiation pattern and gain are similar to a matched quarter – wave monopole. This antenna meets MIL-A-25707 and is designed to IFF and / or TACAN applications. All units offer low VSWR, lightweight, and are suitable for high performance aircrafts.

SPECIFICAITONS

MODEL NUMBER	FREQUENCY (MHz)	PATTERN	MAXIMUM VSWR	POLARIZATION	PEAK POWER (WATTS)	INPUT INTERFACE
C390-152	960-1220	Omnidirectional	1.8 (960-1000 MHz) 1.6 (1000 – 1100 MHz) 1.8 (1100 – 1200 MHz)	Vertical	4000	HN

Data subject to change without notice



MICROWAVE ENGINEERING CORPORATION
1551 OSGOOD STREET, NORTH ANDOVER, MA 01845 • TEL (978) 685-2776 • FAX (978) 975-4363
Website: www.microwaveeng.com, Email: sales@microwaveeng.com



GPS ANTENNAS

DATA SHEET
No. B115
9 of 10

- DUAL - FREQUENCY L1 / L2
- CIRCULARLY POLARIZED
- HEMISPHERICAL COVERAGE
- FLUSH - MOUNTED

P/N: 5010

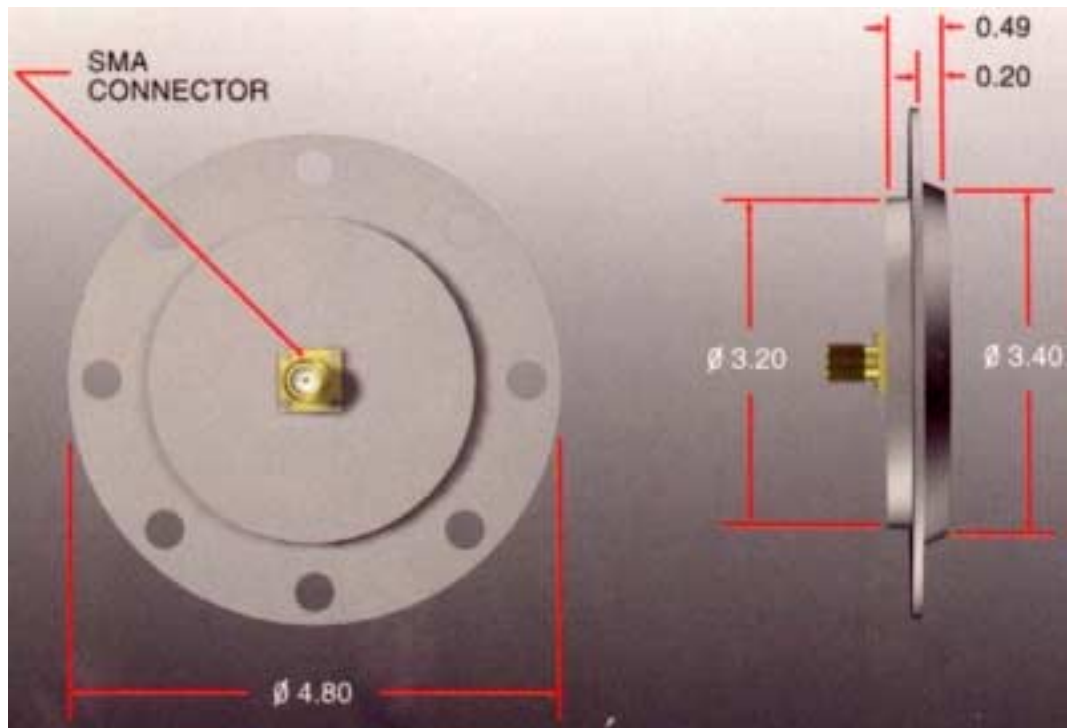

DESCRIPTION

MEC's GPS antenna operates at both L1 and L2 frequencies. This antenna is a flush-mounted design providing hemispherical coverage with excellent gains at low elevation angles. Its low-profile configuration makes this antenna suitable for aircraft, helicopters and mobile vehicles.

SPECIFICATIONS

MODEL NUMBER	FREQUENCY (MHz)	GAIN (dBiC) (elevation angles $\geq 10^\circ$)	MAXIMUM VSWR	POLARIZATION	INPUT INTERFACE
5010	L1 : 1575.42 \pm 10 MHz L2 : 1227.60 \pm 10 MHz	≥ -3.5 ≥ -3.5	2.0 2.0	RCP	TNC

Data subject to change without notice



MICROWAVE ENGINEERING CORPORATION
 1551 OSGOOD STREET, NORTH ANDOVER, MA 01845 • TEL (978) 685-2776 • FAX (978) 975-4363
 Website: www.microwaveeng.com, Email: sales@microwaveeng.com



2.4 GHz DIPOLE ANTENNAS

DATA SHEET
No. B115
10 of 10

- VERTICALLY POLARIZED
- OMNIDIRECTIONAL PATTERN

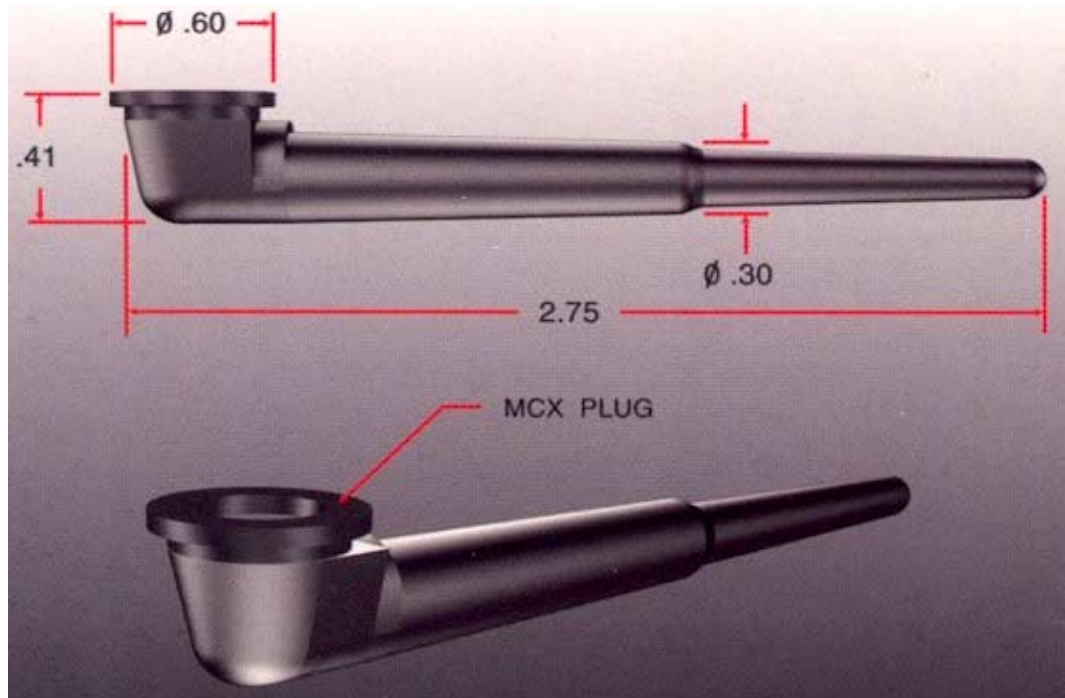

P/N: 6025

DESCRIPTION

MEC's 2.4 GHz dipole antenna features omnidirectional azimuth pattern with vertical polarization. This antenna is suitable for indoor wireless communications such as Wireless LAN systems for personal computers.

SPECIFICATIONS

MODEL NUMBER	FREQUENCY (MHz)	PEAK GAIN (dB)	MAXIMUM VSWR	POLARIZATION	CW POWER (WATTS)	INPUT INTERFACE
6025	2.4 – 2.5	2.0	1.5	Vertical	1	MCX plug

Data subject to change without notice



MICROWAVE ENGINEERING CORPORATION
1551 OSGOOD STREET, NORTH ANDOVER, MA 01845 • TEL (978) 685-2776 • FAX (978) 975-4363
Website: www.microwaveeng.com, Email: sales@microwaveeng.com